

**75 Ω RF Digital Attenuator**  
**4-bit, 15 dB, DC – 2.0 GHz**

### Features

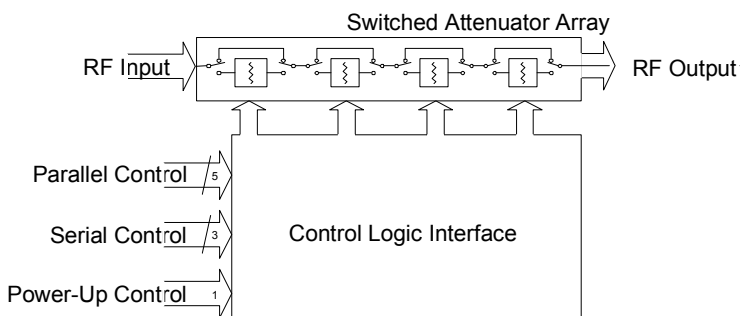
- Attenuation: 1.0 dB steps to 15 dB
- Flexible parallel and serial programming interfaces
  - Parallel latched or direct mode
- High attenuation accuracy and linearity over temperature and frequency
- Unique power-up state selection
- Very low power consumption
- Single-supply operation
- Positive CMOS control logic
- 75 Ω impedance
- Packaged in a 20 Lead 4x4 mm QFN

### Product Description

The SP43404 is a high linearity, 4-bit RF Digital Step Attenuator (DSA) covering a 15 dB attenuation range in 1.0 dB steps. This 75-ohm RF DSA provides both parallel (latched or direct mode) and serial CMOS control interface, operates on a single 3-volt supply and maintains high attenuation accuracy over frequency and temperature. It also has a unique control interface that allows the user to select an initial attenuation state at power-up. The SP43404 exhibits very low insertion loss and low power consumption. This functionality is delivered in a 4x4 mm QFN footprint.

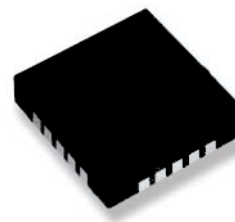
The SP43404 is manufactured on SIPAT's CMOS process, a patented variation of silicon-on-insulator (SOI) technology on a sapphire substrate, offering the performance of GaAs with the economy and integration of conventional CMOS.

**Figure 1. Functional Schematic Diagram**



**Figure 2. Package Type**

20 Lead 4x4 mm QFN



**Table 1. Electrical Specifications @ +25°C, V<sub>DD</sub> = 3.0 V**

Parameter	Test Conditions	Frequency	Minimum	Typical	Maximum	Units
Operation Frequency			DC		2000	MHz
Insertion Loss <sup>1</sup>		DC ≤ 1.2 GHz	-	1.4	1.95	dB
Attenuation Accuracy	Any Bit or Bit Combination	DC ≤ 1.2 GHz	-	-	±(0.25+ 7% of atten setting)	dB
1 dB Compression <sup>3,4</sup>		1 MHz ≤ 1.2 GHz	30	34	-	dBm
Input IP <sub>3</sub> <sup>1,2,4</sup>	Two-tone inputs up to +18 dBm	1 MHz ≤ 1.2 GHz	-	52	-	dBm
Return Loss	Z <sub>0</sub> = 75 ohms	DC ≤ 1.2 GHz	10	13	-	dB
Switching Speed	50% control		-	-	1	μs

- Notes: 1. Device Linearity will begin to degrade below 1MHz  
 2. Max input rating in Table 3 & Figures on Pages 4 to 6 for data across frequency.  
 3. Note Absolute Maximum in Table 3.  
 4. Measured in a 50 Ω system.

Figure 15. Pin Configuration (Top View)

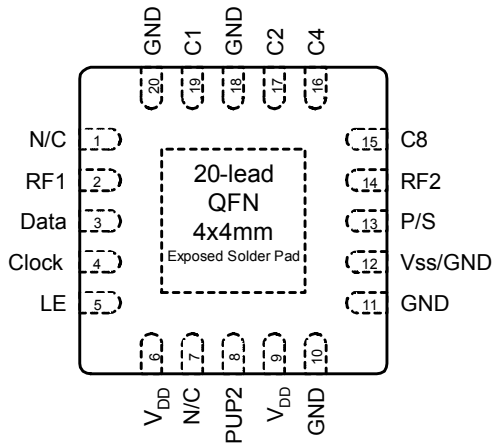


Table 2. Pin Descriptions

Pin No.	Pin Name	Description
1	N/C	No connect
2	RF1	RF port (Note 1).
3	Data	Serial interface data input (Note 4).
4	Clock	Serial interface clock input.
5	LE	Latch Enable input (Note 2).
6	V <sub>DD</sub>	Power supply pin.
7	N/C	No connect
8	PUP2	Power-up selection bit.
9	V <sub>DD</sub>	Power supply pin.
10	GND	Ground connection.
11	GND	Ground connection.
12	V <sub>SS</sub> / GND	Negative supply voltage or GND connection (Note 3)
13	P/S	Parallel/Serial mode select.
14	RF2	RF port (Note 1).
15	C8	Attenuation control bit, 8 dB.
16	C4	Attenuation control bit, 4 dB.
17	C2	Attenuation control bit, 2 dB.
18	GND	Ground connection.
19	C1	Attenuation control bit, 1 dB.
20	GND	Ground for proper operation
Paddle	GND	Ground for proper operation

- Notes: 1. Both RF ports must be held at 0 V<sub>DC</sub> or DC blocked with an external series capacitor.  
 2. Latch Enable (LE) has an internal 100 kΩ resistor to V<sub>DD</sub>.  
 3. Connect pin 12 to GND to enable internal negative voltage generator. Connect pin 12 to V<sub>SS</sub> (-V<sub>DD</sub>) to bypass and disable internal negative voltage generator.  
 4. Place a 10 kΩ resistor in series, as close to pin as possible to avoid frequency resonance. See "Resistor on 3" paragraph

### Exposed Solder Pad Connection

The exposed solder pad on the bottom of the package must be grounded for proper device operation.

Table 3. Absolute Maximum Ratings

Symbol	Parameter/Conditions	Min	Max	Units
V <sub>DD</sub>	Power supply voltage	-0.3	4.0	V
V <sub>I</sub>	Voltage on any input	-0.3	V <sub>DD</sub> +0.3	V
T <sub>ST</sub>	Storage temperature range	-65	150	°C
P <sub>IN</sub>	Input power (50Ω)		+30	dBm
V <sub>ESD</sub>	ESD voltage (Human Body Model)		500	V

Exceeding absolute maximum ratings may cause permanent damage. Operation should be restricted to the limits in the Operating Ranges table. Operation between operating range maximum and absolute maximum for extended periods may reduce reliability.

Table 4. Operating Ranges

Parameter	Min	Typ	Max	Units
V <sub>DD</sub> Power Supply Voltage	2.7	3.0	3.3	V
I <sub>DD</sub> Power Supply Current			100	μA
Digital Input High	0.7xV <sub>DD</sub>			V
Digital Input Low			0.3xV <sub>DD</sub>	V
Digital Input Leakage			1	μA
Input Power			+24	dBm
Temperature range	-40		85	°C

### Electrostatic Discharge (ESD) Precautions

When handling this CMOS device, observe the same precautions that you would use with other ESD-sensitive devices. Although this device contains circuitry to protect it from damage due to ESD, precautions should be taken to avoid exceeding the rate specified in Table 3.

### Latch-Up Avoidance

Unlike conventional CMOS devices, CMOS devices are immune to latch-up.

### Switching Frequency

The SP43404 has a maximum 25 kHz switching rate.

### Resistor on Pin 3

A 10 kΩ resistor on the input to Pin 3 (see Figure 5) will eliminate package resonance between the RF input pin and the digital input. Specified attenuation error versus frequency performance is dependent upon this condition.

## Evaluation Kit

The Digital Attenuator Evaluation Kit was designed to ease customer evaluation of the SP43404 DSA.

J9 is used in conjunction with the supplied DC cable to supply  $V_{DD}$ , GND, and  $-V_{DD}$ . If use of the internal negative voltage generator is desired, then connect  $-V_{DD}$  (black banana plug) to ground. If an external  $-V_{DD}$  is desired, then apply  $-3V$ .

J1 should be connected to the LPT1 port of a PC with the supplied control cable. The evaluation software is written to operate the DSA in serial mode, so switch 7 (P/S) on the DIP switch SW1 should be ON with all other switches off. Using the software, enable or disable each attenuation setting to the desired combined attenuation. The software automatically programs the DSA each time an attenuation state is enabled or disabled.

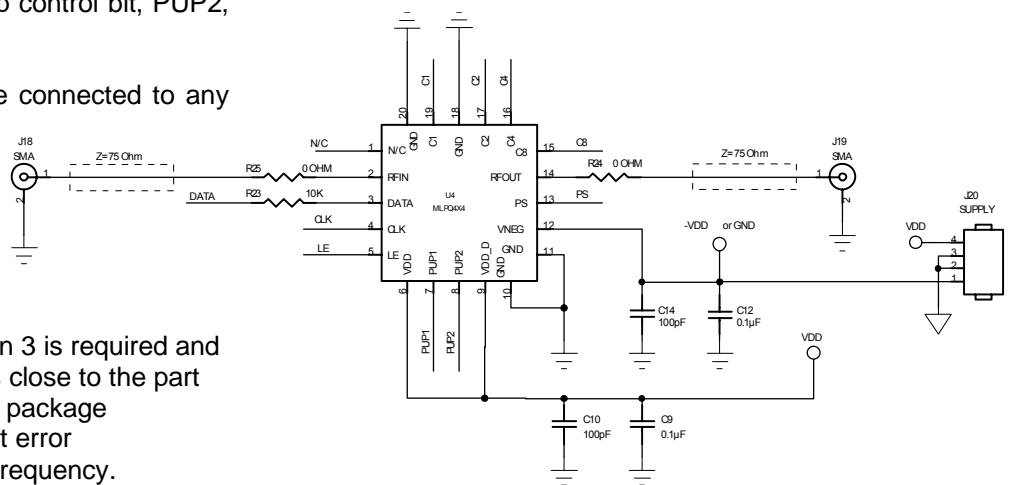
Note: Jumper J6 supplies power to the evaluation board support circuits.

To evaluate the Power Up options, first disconnect the control cable from the evaluation board. The control cable must be removed to prevent the PC port from biasing the control pins.

During power up with P/S=1 high and LE=1, the default power-up signal attenuation is set to the value present on the four control bits on the four parallel data inputs (C1 to C8). This allows any one of the 32 attenuation settings to be specified as the power-up state.

During power up with P/S=0 high and LE=0, the control bits are automatically set to one of two possible values presented through the PUP interface. These two values are selected by the power-up control bit, PUP2, as shown in Table 6.

Pins 1 and 7 are open and may be connected to any bias.



Note: Resistor on pin 3 is required and should be placed as close to the part as possible to avoid package resonance and meet error specifications over frequency.

Figure 4. Evaluation Board Layout

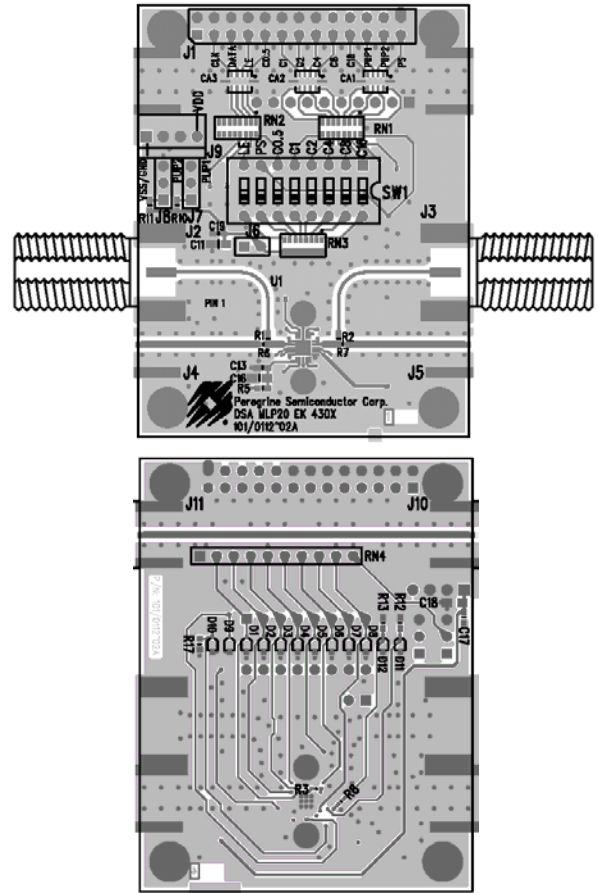


Figure 5. Evaluation Board Schematic

Typical Performance Data @ 25°C,  $V_{DD} = 3.0\text{ V}$

Figure 6. Insertion Loss ( $Z_0=75\text{ ohms}$ )

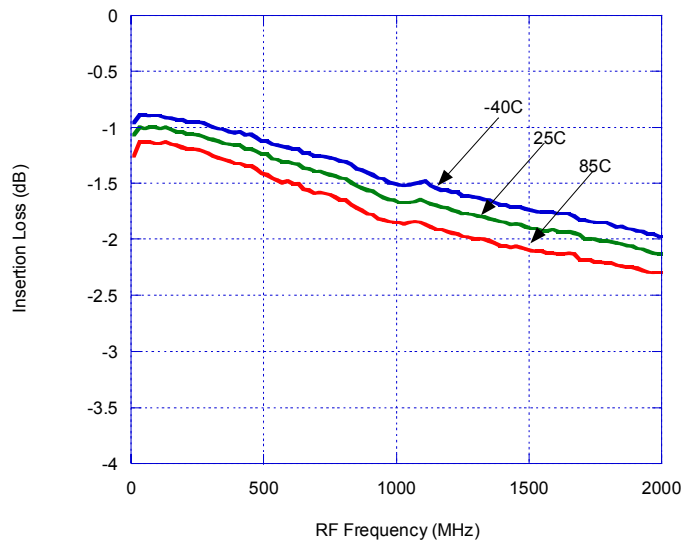


Figure 7. Attenuation at Major steps

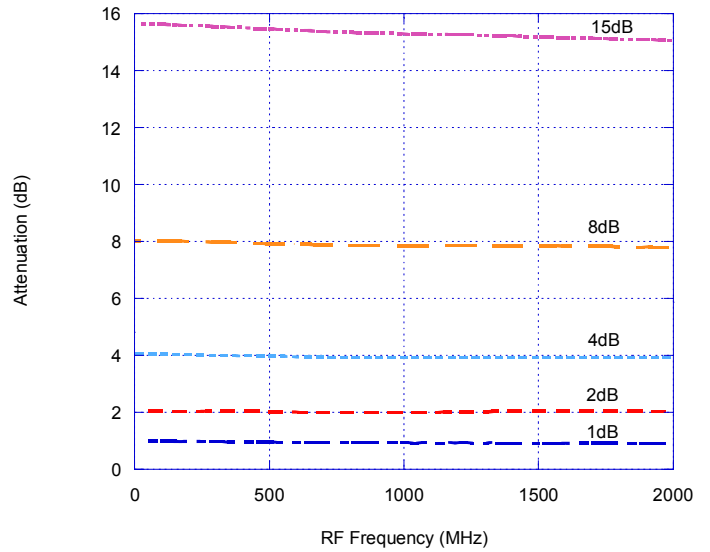


Figure 8. Input Return Loss at Major Attenuation Steps ( $Z_0=75\text{ ohms}$ )

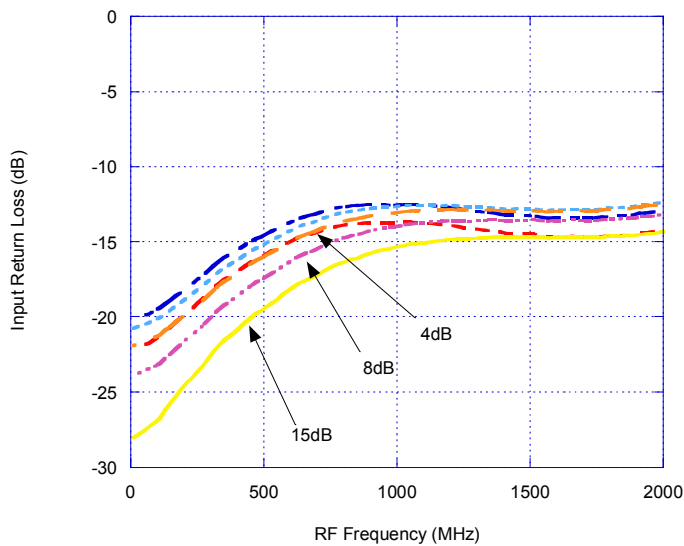
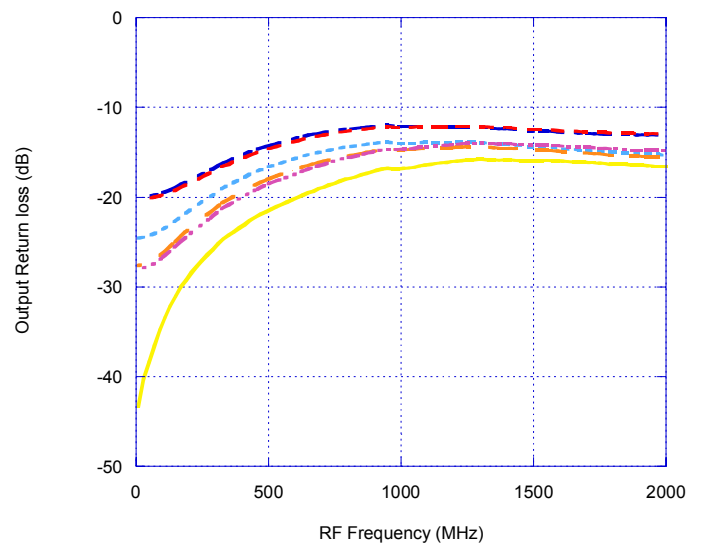


Figure 9. Output Return Loss at Major Attenuation Steps ( $Z_0=75\text{ ohms}$ )



Typical Performance Data @ 25°C, V<sub>DD</sub> = 3.0 V

Figure 10. Attenuation Error Vs. Frequency

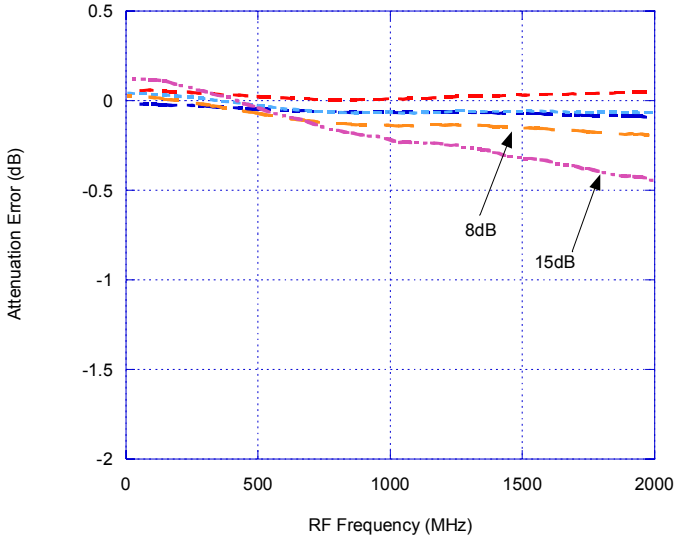


Figure 11. Attenuation Error Vs. Attenuation Setting

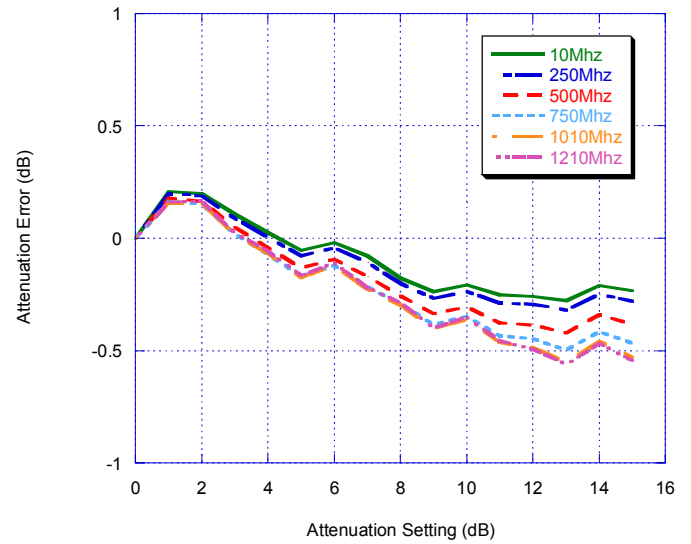


Figure 12. Input IP3 vs. Frequency (Z<sub>o</sub>=50 ohms)

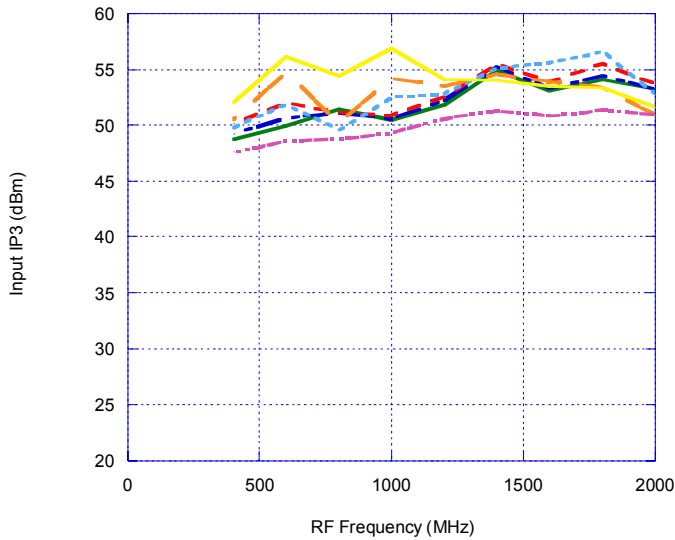
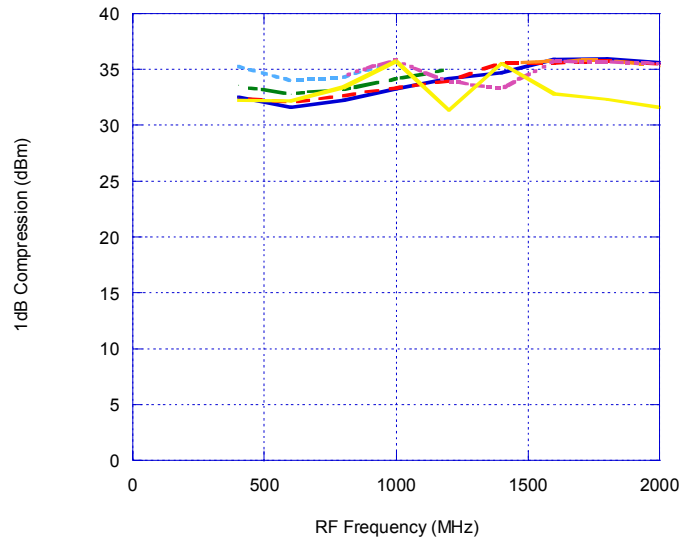


Figure 13. Input 1 dB Compression (Z<sub>o</sub>=50 ohms)



Note: Positive attenuation error indicates higher attenuation than target value

Typical Performance Data @ 25°C, V<sub>DD</sub> = 3.0 V

Figure 14. Attenuation Error Vs. Attenuation Setting

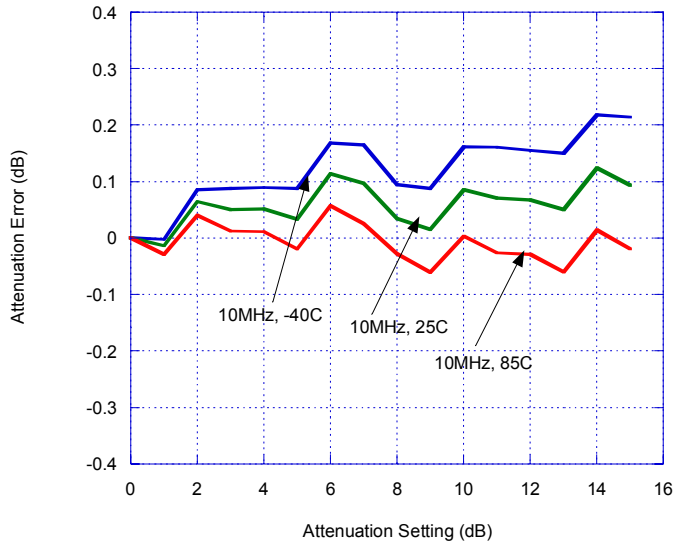


Figure 15. Attenuation Error Vs. Attenuation Setting

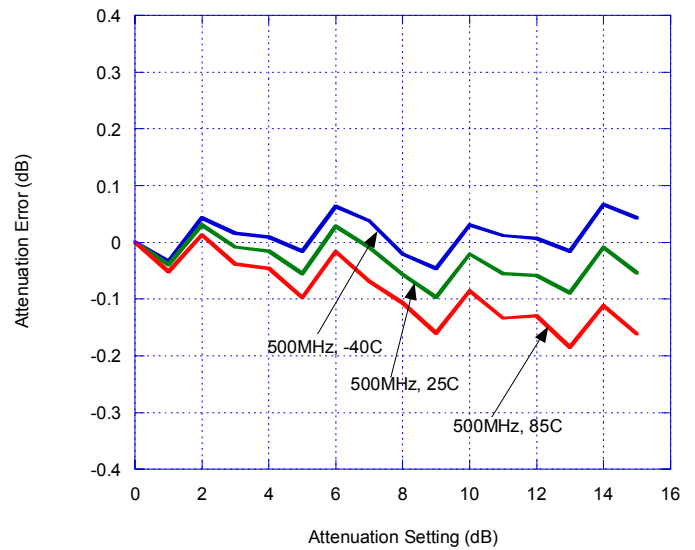


Figure 16. Attenuation Error Vs. Attenuation Setting

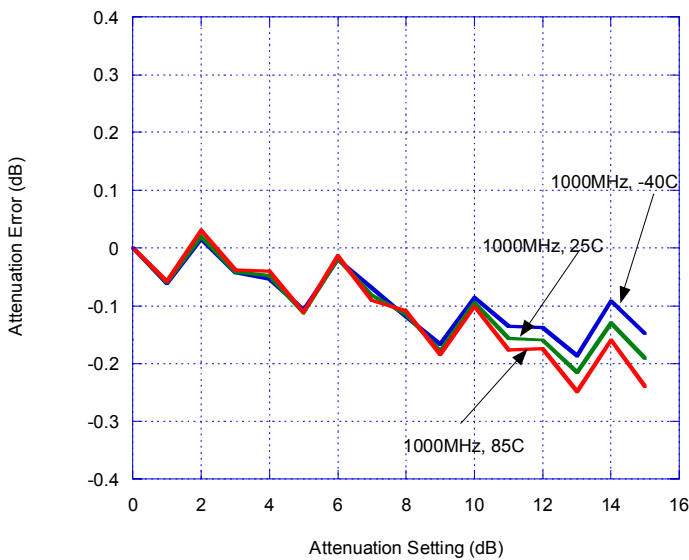
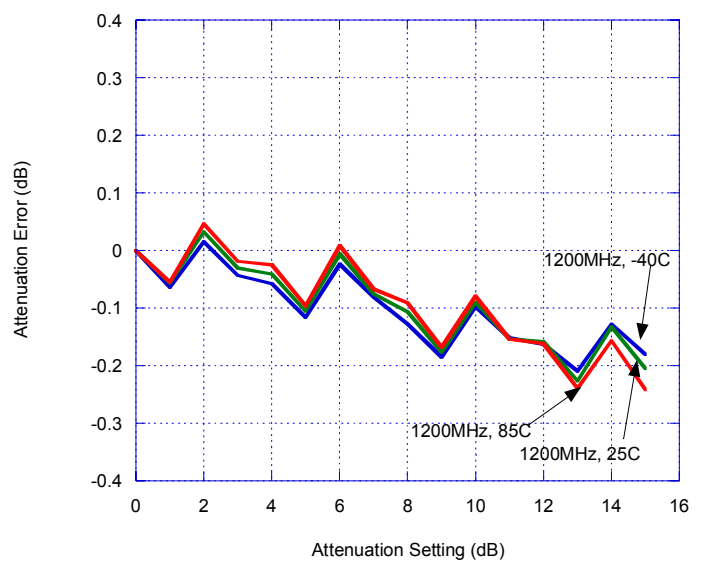


Figure 17. Attenuation Error Vs. Attenuation Setting



Note: Positive attenuation error indicates higher attenuation than target value

## Programming Options

### Parallel/Serial Selection

Either a parallel or serial interface can be used to control the SP43404. The P/S bit provides this selection, with P/S=LOW selecting the parallel interface and P/S=HIGH selecting the serial interface.

### Parallel / Direct Mode Interface

The parallel interface consists of four CMOS-compatible control lines that select the desired attenuation state, as shown in Table 5.

The parallel interface timing requirements are defined by Figure 19 (Parallel Interface Timing Diagram), Table 9 (Parallel Interface AC Characteristics), and switching speed (Table 1).

For *latched* parallel programming, the Latch Enable (LE) should be held LOW while changing attenuation state control values, then pulse LE HIGH to LOW (per Figure 19) to latch new attenuation state into device.

For *direct* parallel programming, the Latch Enable (LE) line should be pulled HIGH. Changing attenuation state control values will change device state to new attenuation. Direct Mode is ideal for manual control of the device (using hardware, switches, or jumpers).

**Table 5. Truth Table**

P/S	C8	C4	C2	C1	Attenuation State
0	0	0	0	0	Reference Loss
0	0	0	0	1	1 dB
0	0	0	1	0	2 dB
0	0	1	0	0	4 dB
0	1	0	0	0	8 dB
0	1	1	1	1	15 dB

Note: Not all 16 possible combinations of C1-C8 are shown in table

### Serial Interface

The SP43404's serial interface is a 6-bit serial-in, parallel-out shift register buffered by a transparent latch. The latch is controlled by three CMOS-compatible signals: Data, Clock, and Latch Enable (LE). The Data and Clock inputs allow data to be

serially entered into the shift register, a process that is independent of the state of the LE input.

The LE input controls the latch. When LE is HIGH, the latch is transparent and the contents of the serial shift register control the attenuator. When LE is brought LOW, data in the shift register is latched.

The shift register should be loaded while LE is held LOW to prevent the attenuator value from changing as data is entered. The LE input should then be toggled HIGH and brought LOW again, latching the new data. The start bit (B5) and stop bit (B0) of the data should always be low to prevent an unknown state in the device. The timing for this operation is defined by Figure 18 (Serial Interface Timing Diagram) and Table 8 (Serial Interface AC Characteristics).

### Power-up Control Settings

The SP43404 always assumes a specifiable attenuation setting on power-up. This feature exists for both the Serial and Parallel modes of operation, and allows a known attenuation state to be established before an initial serial or parallel control word is provided.

When the attenuator powers up in Serial mode (P/S=1), the four control bits are set to whatever data is present on the four parallel data inputs (C1 to C8). This allows any one of the 16 attenuation settings to be specified as the power-up state.

When the attenuator powers up in Parallel mode (P/S=0) with LE=0, the control bits are automatically set to one of two possible values. These two values are selected by the power-up control bit, PUP2, as shown in Table 6 (Power-Up Truth Table, Parallel Mode).

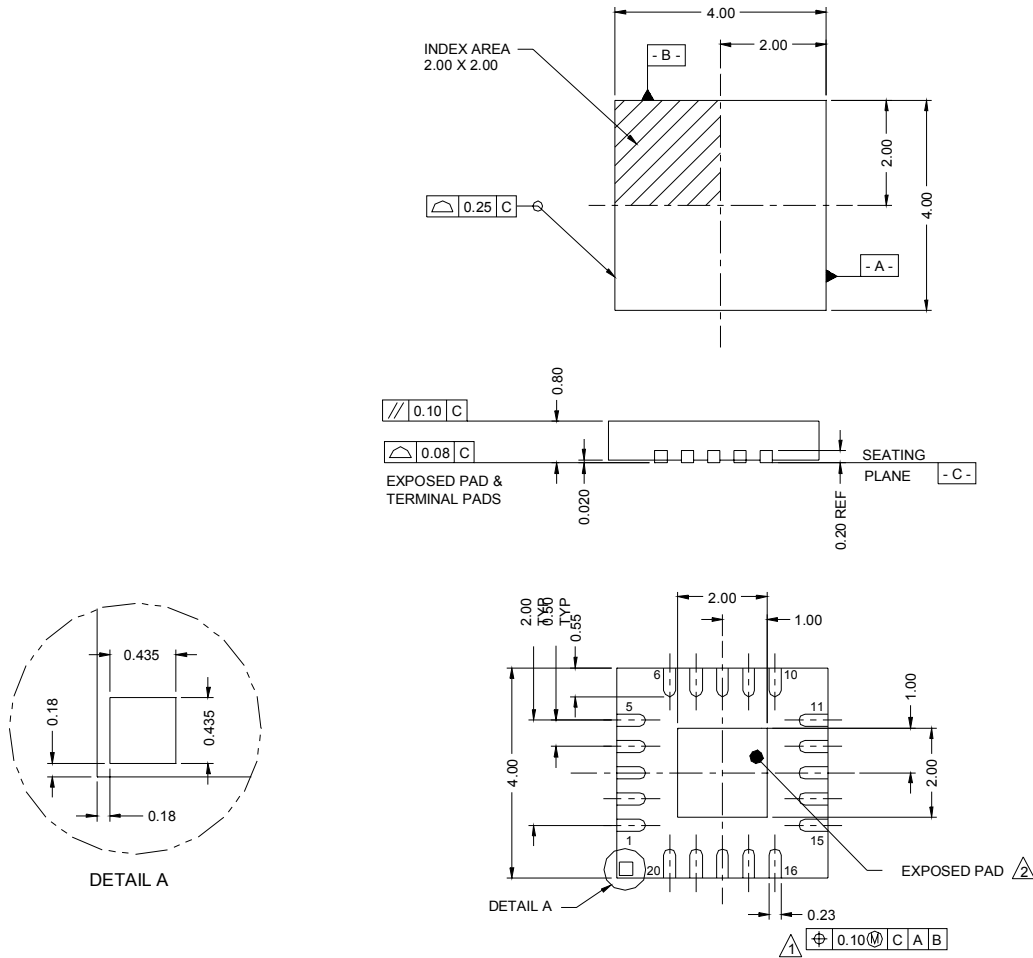
**Table 6. Power-Up Truth Table, Parallel Interface Mode**

P/S	LE	PUP2	Attenuation State
0	0	0	Reference Loss
0	0	1	8 dB
0	1	X	Defined by C1-C8

Note: Power up with LE=1 provides normal parallel operation with C1-C8, and PUP2 is not active.

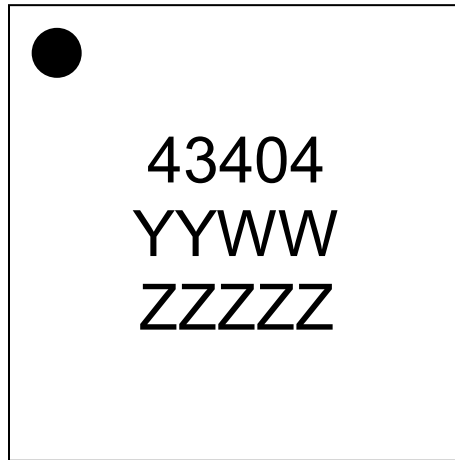


**Figure 20. Package Drawing**  
20 Lead 4x4 mm QFN



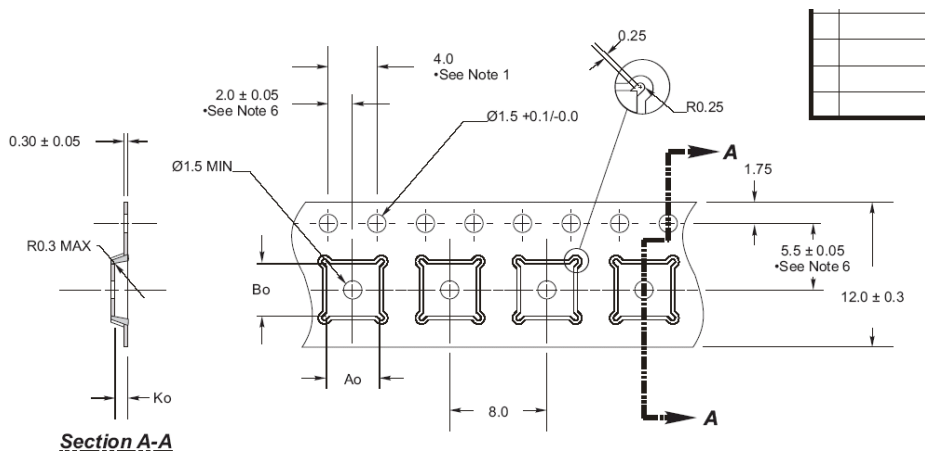
1. Dimension applies to metallized terminal and is measured between 0.25 and 0.30 from terminal tip.
2. Coplanarity applies to the exposed heat sink slug as well as the terminals.
3. Dimensions are in millimeters.

Figure 21. Marking Specifications



YYWW = Date Code  
ZZZZZ = Last five digits of PSC Lot Number

Figure 22. Tape and Reel Drawing



Ao = 4.35 mm  
Bo = 4.35 mm  
Ko = 1.1 mm

- Notes:
1. 10 sprocket hole pitch cumulative tolerance  $\pm 0.2$ .
  2. Camber not to exceed 1mm in 100mm.
  3. Material: PS + C.
  4. Ao and Bo measured as indicated.
  5. Ko measured from a plane on the inside bottom of the pocket to the top surface of the carrier.
  6. Pocket position relative to sprocket hole measured as true position of pocket, not pocket hole.