

Product Description

The SP42742 is an SPDT CMOS Switch designed for Broadband applications such as CATV, DTV, Multi-Tuner DVR (Digital Video Recorder), Set-top Box, PCTV and Game Boxes. It meets FCC 15.115 spec of 80 dB isolation @ 216 MHz and offers high isolation and low insertion loss in both a powered and a unique unpowered default state. The SP42742 covers a broad frequency range from 5 MHz to beyond 2200 MHz with a single positive supply and CMOS control. It provides a smaller, cost effective, more reliable and manufacturable alternative to mechanical relays in set-top box applications.

The SP42742 is manufactured on SIPAT's CMOS process, a patented variation of silicon-on-insulator (SOI) technology on a sapphire substrate, offering the performance of GaAs with the economy and integration of conventional CMOS.

75 Ω Terminated, 5 - 2200 MHz SPDT
CATV CMOS Switch
Featuring Unpowered Operation

Features

- Meets FCC 15.115 spec of 80 dB isolation @ 216 MHz
- Unpowered operational state
- 3500 V HBM ESD tolerance, All Pins
- CTB performance of 90 dBc
- High isolation: 63 dB at 1000 MHz
- Low insertion loss: typically 0.5 dB at 5 MHz, 0.8 dB at 1000 MHz
- CMOS single-pin control with logic select
- Single +3 volt supply operation
- Low current consumption: 8 μ A

Figure 1. Functional Diagram

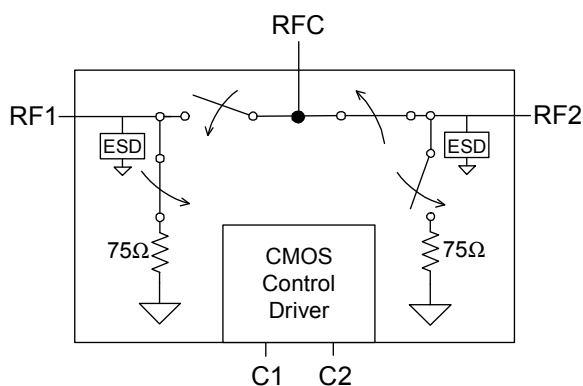

Figure 2. Package Type

4x4 mm 20-lead QFN

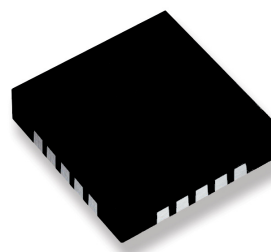

Table 1. Electrical Specifications @ +25 °C, V_{DD} = +3 V (Z_S = Z_L = 75 Ω)

Parameter	Condition	Minimum	Typical	Maximum	Units
Operating Frequency		5		2200	MHz
RF1-RFC Insertion Loss	220 MHz		0.45	0.55	dB
	550 MHz		0.55	0.65	dB
	810 MHz		0.7	0.8	dB
	2200 MHz		1.7	1.8	dB
RF2-RFC Insertion Loss	220 MHz		0.7	0.8	dB
	550 MHz		0.8	0.9	dB
	810 MHz		0.9	1	dB
	2200 MHz		1.8	1.9	dB
Isolation RF1 to RF2 (RFC-RF1 ON)	220 MHz	81	94		dB
	550 MHz	77	82		dB
	810 MHz	71.5	76		dB
	2200 MHz	50	53.6		dB
Isolation RF1 to RF2 (RFC-RF2 ON)	220 MHz	81	92		dB
	550 MHz	75	79		dB
	810 MHz	70.5	75		dB
	2200 MHz	50	53		dB
Isolation RF1 to RFC (RFC-RF2 ON)	220 MHz	71	74		dB
	550 MHz	64	66		dB
	810 MHz	62	64		dB
	2200 MHz	52	57		dB
Isolation RF2 to RFC (RFC-RF1 ON)	220 MHz	70.5	73		dB
	550 MHz	64	66		dB
	810 MHz	61.5	63		dB
	2200 MHz	51	55		dB
IP2 RF1/RF2 ²	5 MHz – 1000 MHz		90/90		dBm
IIP3 RF1/RF2 ²	5 MHz – 1000 MHz		53/53		dBm
Input 1 dB Compression RF1/RF2 ²	1000 MHz	30/24.5	32/26.5		dBm
CTB / CSO (Powered/Unpowered)	77 & 110 channels; Power Out = 44 dBmV		-90 / -77		dBc
Switching time	50 % CTRL to 10 / 90 RF		3		µs
Video Feedthrough ³	5 MHz – 1000MHz		20		mVpp

Table 2. Electrical Characterization (Unpowered Operation)⁵

Parameter	Condition	Minimum	Typical	Maximum	Units
Operating Frequency ¹		5		2200	MHz
Isolation RF1 to RF2 ⁴	220 MHz	81	90.5	-	dB
	550 MHz	77	81.5	-	dB
	810 MHz	70.5	77	-	dB
	2200 MHz	49	52.5	-	dB

- Notes:
1. Device linearity will begin to degrade with input signals below 5 MHz.
 2. Measured in a 50 Ω system.
 3. Measured with a 1 ns risetime, 0/3 V pulse and 500 MHz bandwidth
 4. Minimum per FCC 15.115 spec
 5. See *Figure 9* for Power-Off insertion loss of RFC-RF1

Figure 3. Pin Configuration (Top View)

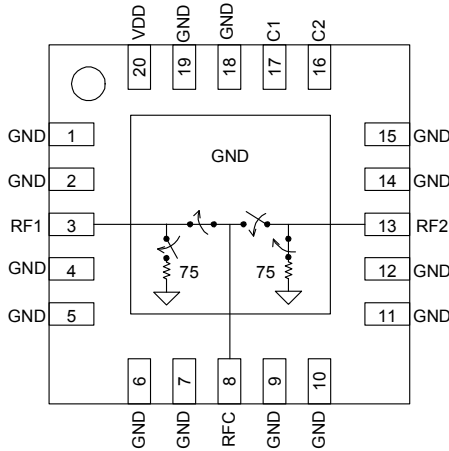

Table 3. Pin Descriptions

No.	Name	Description
1, 2, 4-7, 9-12, 14, 15, 18, 19	GND	RF Ground
3	RF1 ¹	RF I/O
8	RFC ¹	RF Common
13	RF2 ¹	RF I/O
16	C2 ²	Control 2 (or logic select)
17	C1 ²	Control 1 (or logic select)
20	VDD	Supply
Pad	GND	RF Ground Pad

Notes: 1. RF pins 3, 8, and 13 must be at 0 VDC. The RF pins do not require DC blocking capacitors for proper operation if the 0 V DC requirement is met.
2. Pins 16 and 17 can be set for single pin or complementary pin control.

Table 4. Moisture Sensitivity Level and Fabrication Plant

The SP42742 in the 20-lead QFN package is rated MSL1. Please note the difference in fabrication plants for the following ordering codes.

Ordering Code	Moisture Sensitivity Level	Fabrication Plant
SP42742MLIBB	MSL1	2
SP42742MLIBB-Z	MSL1	2
SP42742MLIBA	MSL1	2
SP42742MLIBA-Z	MSL1	2
42742-51	MSL1	1
42742-52	MSL1	1

Table 5. Operating Conditions @ 25 °C

Parameter	Min	Typ	Max	Unit
V _{DD} Power Supply	2.7	3.0	3.3	V
I _{DD} Power Supply Current (V _{DD} = 3 V, V _{CNTL} = 3 V)		8		μA
Control Voltage High	0.7 x V _{DD}		V _{DD}	V
Control Voltage Low	0		0.3 x V _{DD}	V

Table 6. Absolute Maximum Ratings

Symbol	Parameter/Condition	Min	Max	Unit
V _{DD}	Power supply voltage	-0.3	4.0	V
V _I	Voltage on any DC input	-0.3	V _{DD} + 0.3	V
P _{RF}	RF power on RFC, RF1, RF2 Terminated/Through		24/33	dBm
T _{ST}	Storage temperature	-65	+150	°C
T _{OP}	Operating temperature	-40	+85	°C
V _{ESD} (note 1)	HBM ³ ESD Voltage RF Pins		2000	V
	HBM ³ ESD Voltage Digital Pins		500	
	MM ESD Voltage all pins		100	
V _{ESD} (note 2)	HBM ³ ESD Voltage RF Pins		3500	V
	HBM ³ ESD Voltage Digital Pins		3500	
	MM ESD Voltage all pins		150	

Notes: 1. Fabrication plant 1 parts, see Table 4. Please contact factory for fabrication plant details.
2. Fabrication plant 2 parts, see Table 4. Please contact factory for fabrication plant details.
3. ML_STD 883 Method 3015.7

Exceeding absolute maximum ratings may cause permanent damage. Operation should be restricted to the limits in the Operating Ranges table. Operation between operating range maximum and absolute maximum for extended periods may reduce reliability.

Electrostatic Discharge (ESD) Precautions

When handling this CMOS device, observe the same precautions that you would use with other ESD-sensitive devices. Although this device contains circuitry to protect it from damage due to ESD, precautions should be taken to avoid exceeding the rating specified.

Latch-Up Avoidance

Unlike conventional CMOS devices, CMOS devices are immune to latch-up.

Switching Frequency

The SP42742 has a maximum 25 kHz switching rate.

Table 7. Truth Table

V _{DD}	C1 (pin 17)	C2 (pin 16)	RFC – RF1	RFC – RF2
OFF	Low	Low	ON	OFF
ON	Low	Low	ON	OFF
ON	Low	High	OFF	ON
ON	High	Low	OFF	ON
ON	High	High	ON	OFF

Note: A versatile logic table has been established to allow either C1 or C2 act as a single pin control and in either polarity.

Typical Applications

The SP42742 provides the high isolation required by FCC part 15.115 regulation between the television antenna and the cable plant. The advantage of the SP42742 is that device isolation / thru performance is maintained when power is removed. This unique feature makes the SP42742 ideal for set-top box and VCR applications. The SP42742 supports signal flow from RFC to RF1 and RF2 termination in the unpowered state; similar to the powered state with C1=C2 (both high or low).

Figure 4. Typical Application (1 of 4)

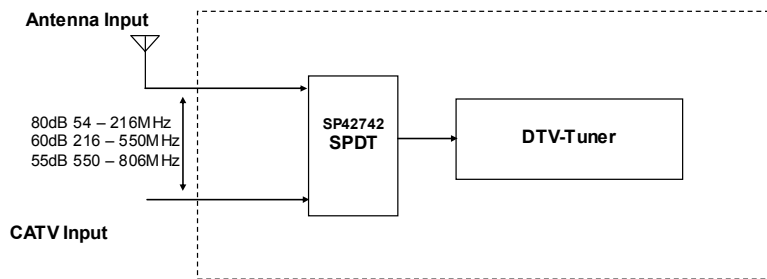

Figure 5. Typical Application (2 of 4)

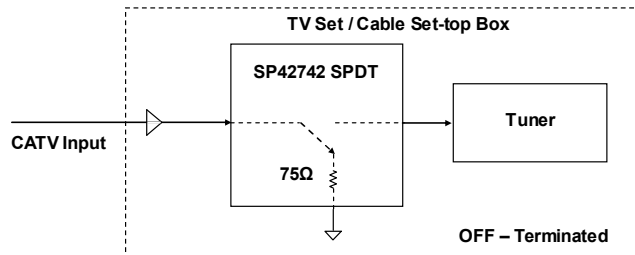

Figure 6. Typical Application (3 of 4)

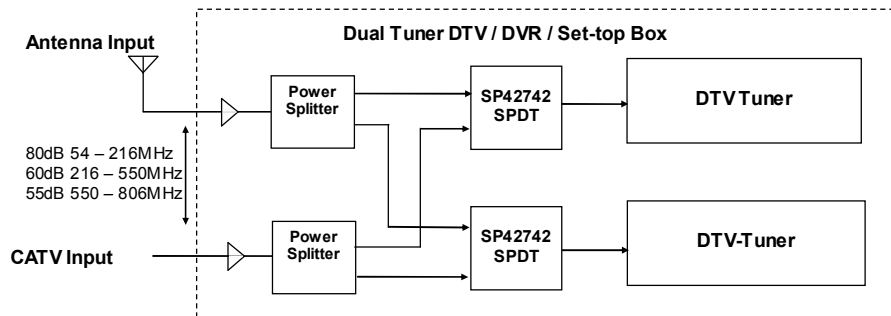
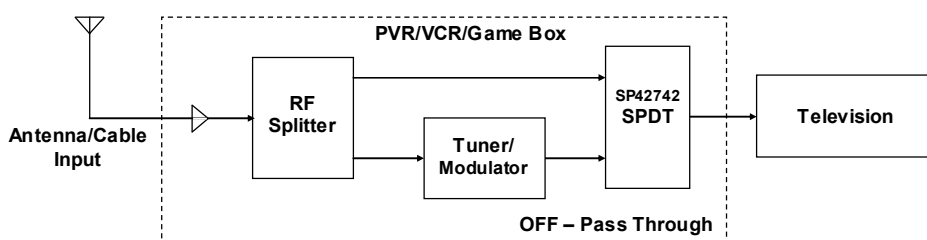

Figure 7. Typical Application (4 of 4)



Typical Performance Data @ 25°C, 75 Ω

Figure 8. Insertion Loss – Power On

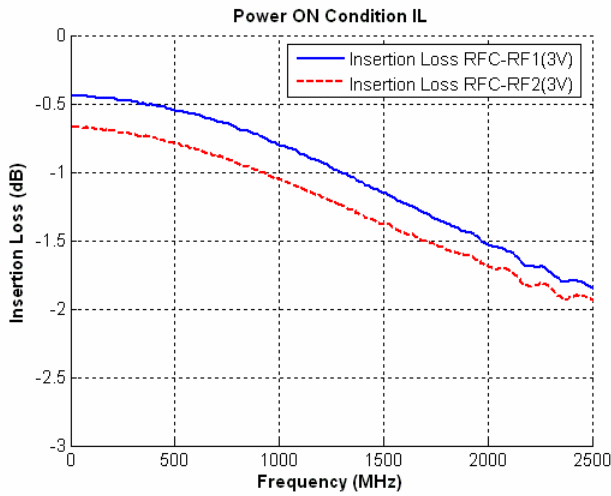

Figure 9. Insertion Loss – Power Off

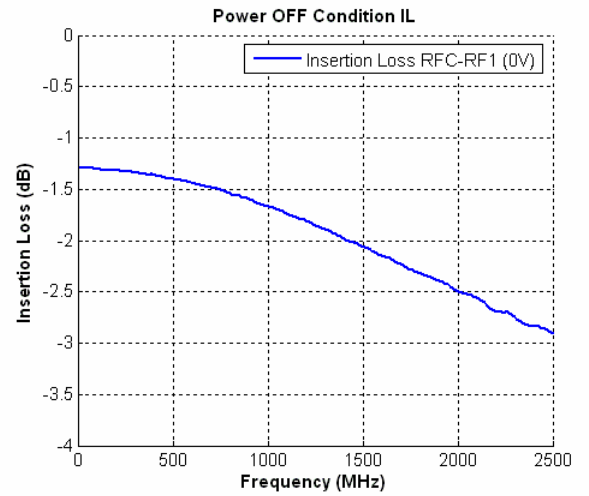

Figure 10. Isolation - Power On

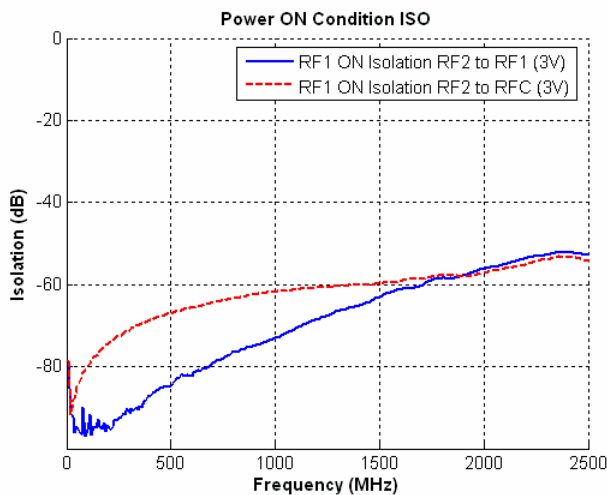
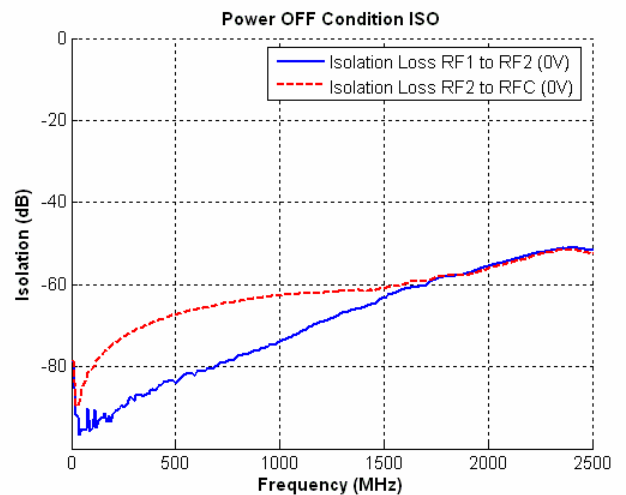

Figure 11. Isolation - Power Off



Typical Performance Data @ 25°C, 75 Ω

Figure 12. Isolation: RF2 – Power On

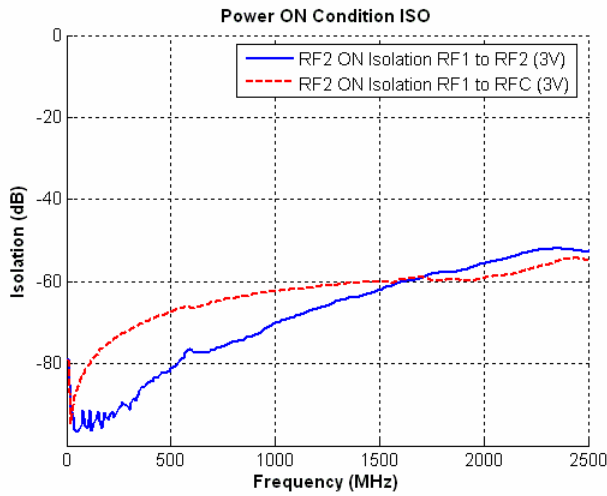

Figure 13. Return Loss: RF1

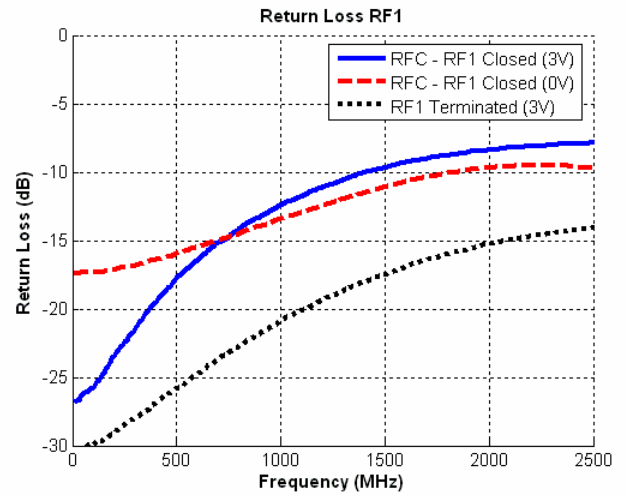

Figure 14. Return Loss: RF2

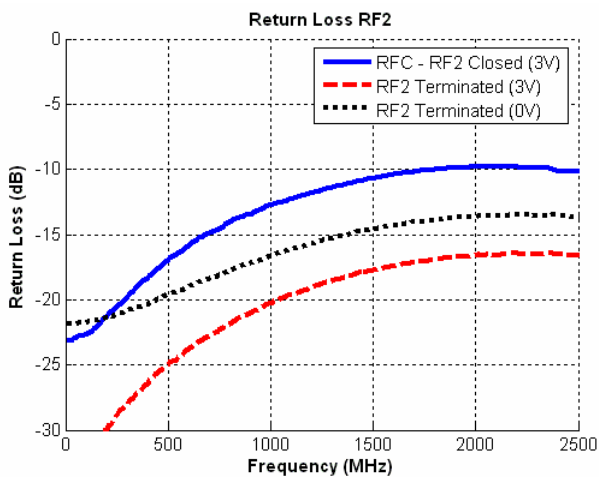
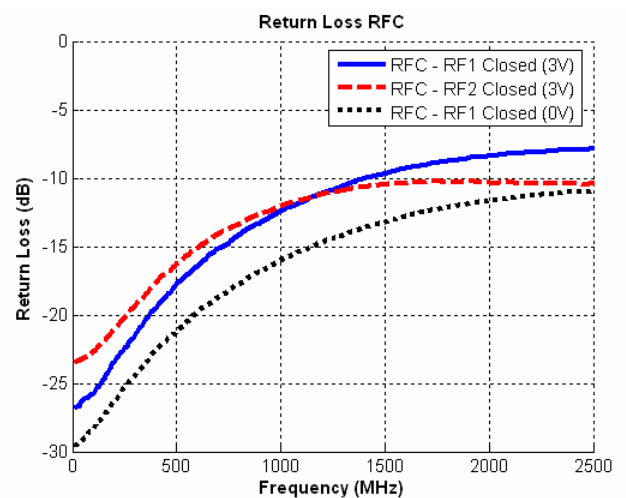

Figure 15. Return Loss: RFC



Typical Performance Data @ 25°C, 75 Ω

Figure 16. Input IP3: RFC-RF1/RF2

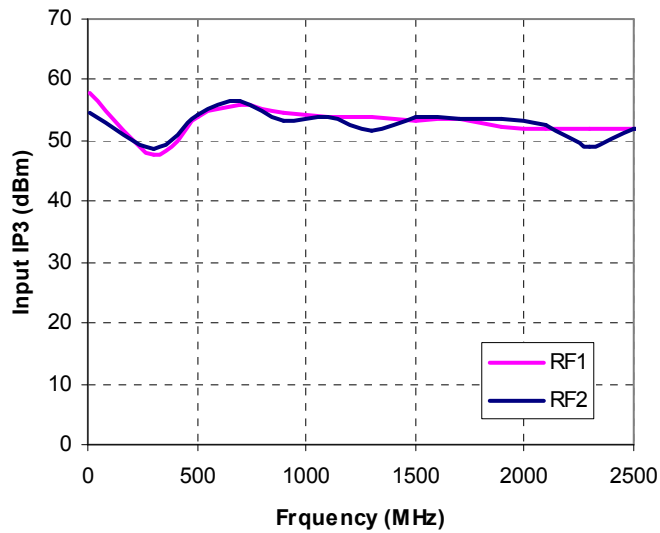

Figure 17. P_1dB Compression: RFC-RF1/RF2

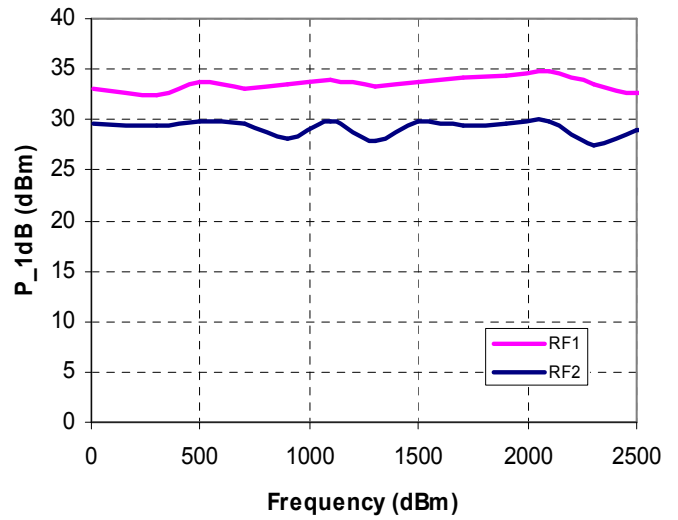
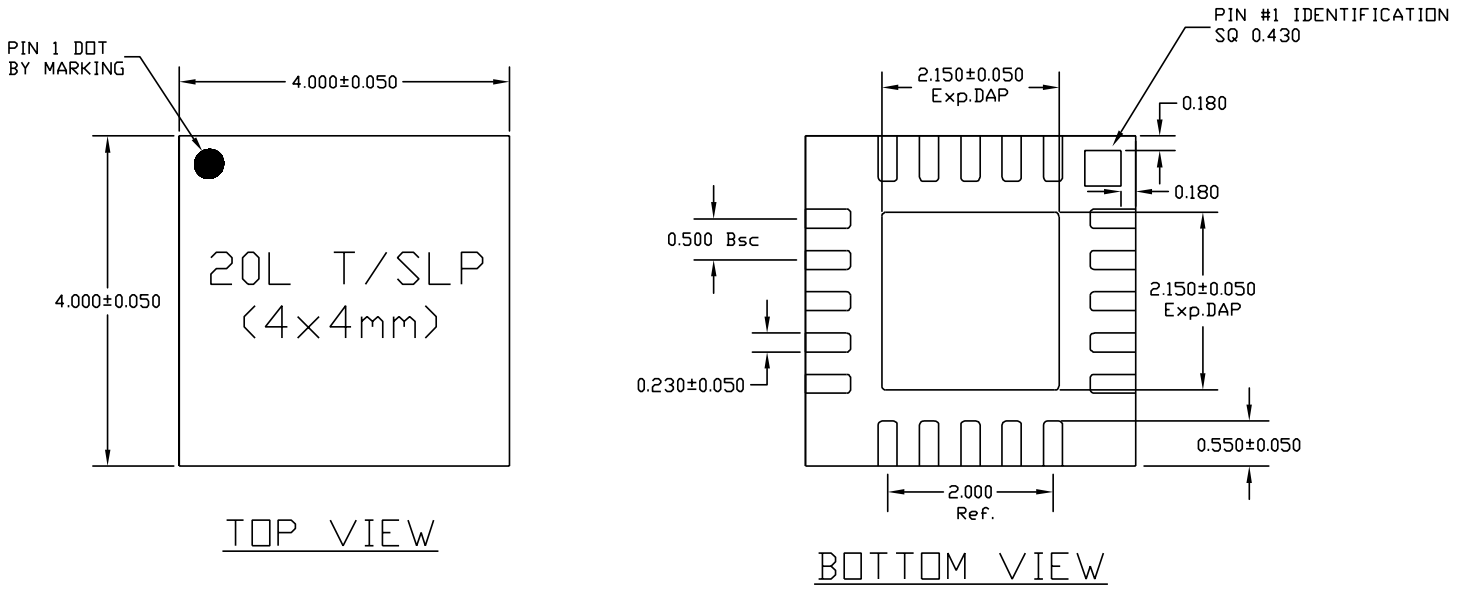

Figure 20. Package Drawing

4x4 mm 20-lead QFN, BOM 19/0106



NOTE:

1) TSLP AND SLP SHARE THE SAME EXPOSE OUTLINE BUT WITH DIFFERENT THICKNESS:

A		TSLP	SLP
	MAX.	0.800	0.900
NOM.	0.750	0.850	
MIN.	0.700	0.800	

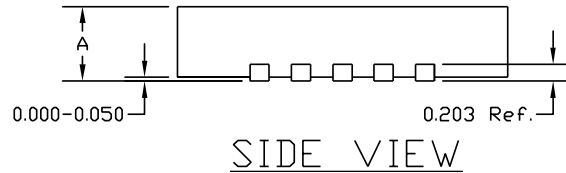
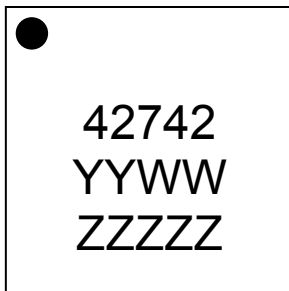
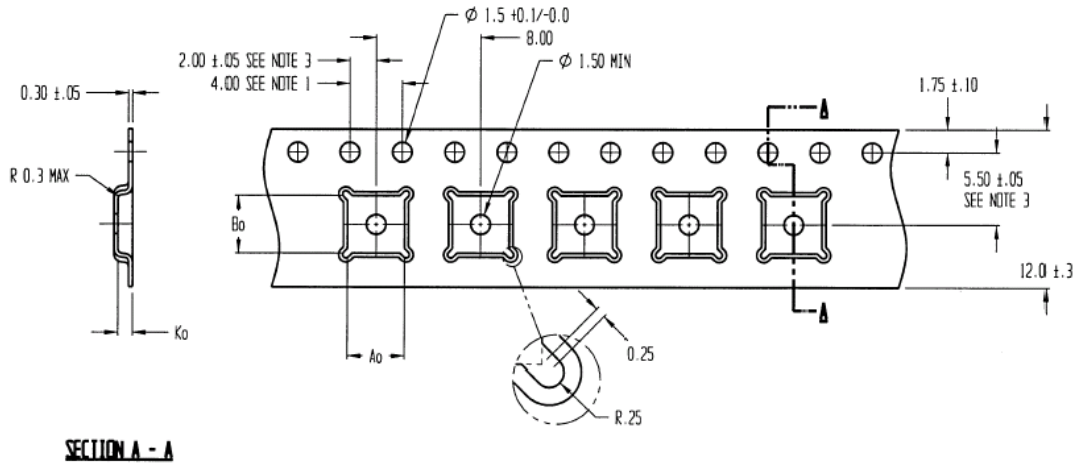

Figure 21. Marking Specification



YYWW = Date Code (Year, Work Week)
ZZZZZ = Last five digits of PSC Lot Number

Figure 22. Tape and Reel Drawing



-----> Tape Feed Direction ----->

NOTES:

1. 10 SPROCKET HOLE PITCH CUMULATIVE TOLERANCE ± 0.2
2. CAMBER IN COMPLIANCE WITH EIA 481
3. POCKET POSITION RELATIVE TO SPROCKET HOLE MEASURED AS TRUE POSITION OF POCKET, NOT POCKET HOLE

$A_0 = 4.35$
 $B_0 = 4.35$
 $K_0 = 1.1$

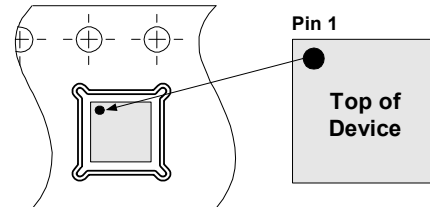

Device Orientation in Tape