



LBN10004 MHz SAW Filter Electrical Characteristic

Specifications

Parameter	Unit	Minimum	Typical	Maximum
Center Frequency	MHz	99.85	100	100.15
Insertion Loss	dB		27.2	29
3 dB Bandwidth	MHz	19	19.10	
40 dB Bandwidth	MHz		19.88	20.0
Passband variation	dB		1.2	1.5
Absolute Delay	usec		3.76	4
Ultimate Rejection	dB	45	50	
Substrate Material		YZ LN		
Ambient Temperature	°C	25		
Package Size		DIP3512 (35.1x12.6x5.2mm ³)		

Typical Performance

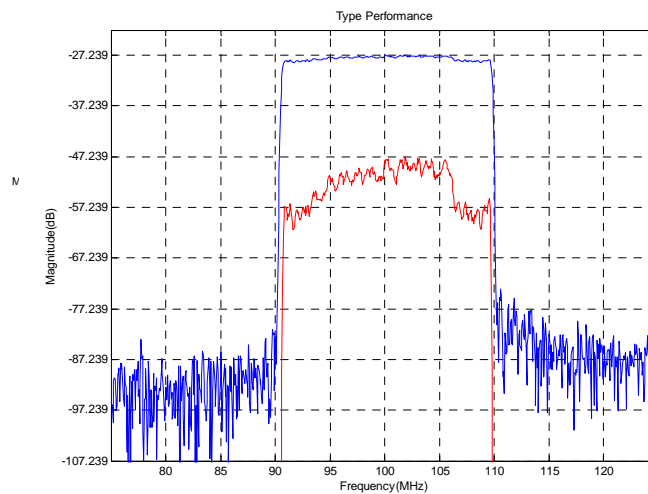

Package Outline

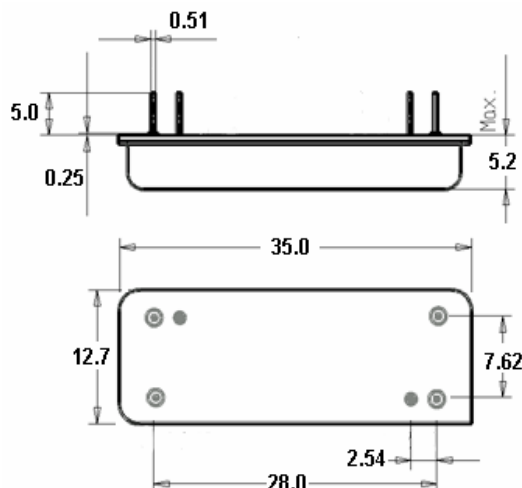

Matching Configuration

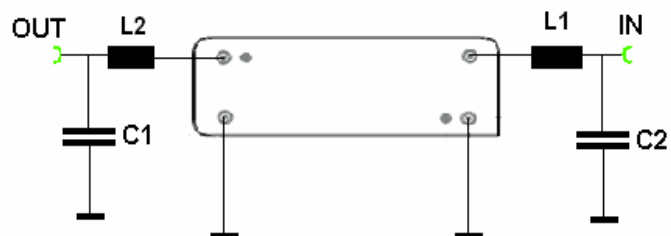

$$L1=L2=82\text{nH}$$

$$C1=C2=20\text{pF}$$

Source/Load Impedance = 50 ohm